



DVM

Technical Data Book

DVM S Indoor Unit

SAMSUNG

1 Nomenclature

1-1. Nomenclature

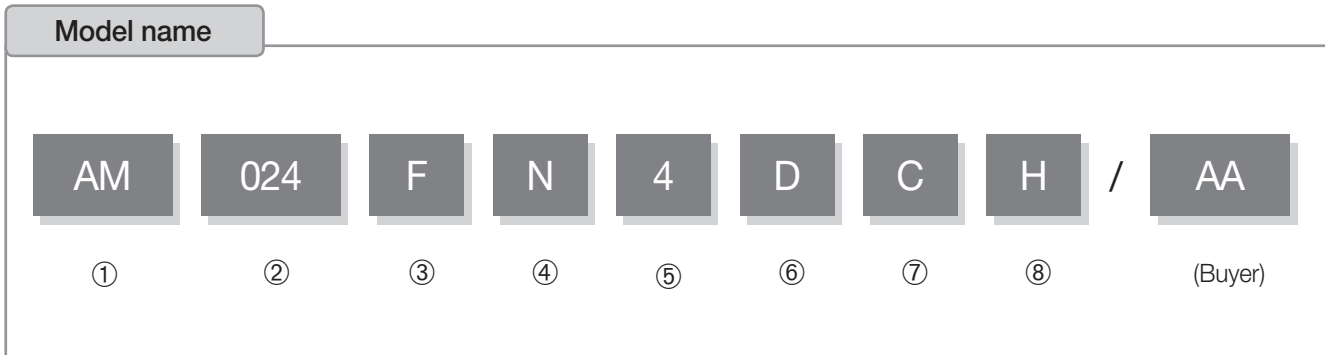

① Classification

AM	DVM
----	-----

② Capacity

kBtu/h (3digits)

③ Version

E	2012
F	2013
H	2014

④ Product Type

X	Outdoor Unit
N	Indoor Unit

⑤ Product Notation

1	1 way cassette
2	2 way cassette
N	4 way cassette (600x600)
4	4 way cassette
L	LSP Duct (Slim Duct)
M	MSP Duct
H	HSP Duct
C	Ceiling
J	Console
F	Floor Standing
T	NEO FORTE
Q	NEO FORTE (EEV)
B	HYDRO UNIT (Floor Standing)
K	FLAT(CEILING TYPE) VTL

⑥ Feature

D	DELUXE
F	FLAGSHIP
G (EHS)	CASCADE (EEV)

⑦ Rating Voltage

C	1Ø, 208~230V, 60Hz
---	--------------------

⑧ Mode

H	Heat Pump (R410a)
R	Heat Recovery (R410a)

2 2 way cassette

2-1. Specifications

1) Technical specifications

Type			2 WAY CASSETTE		2 WAY CASSETTE	
Model			AM018FN2DCH/TC		AM024FN2DCH/TC	
Power Supply			Ø, V, Hz		1,2,208-230,60	
Mode* ¹⁾			-		HP/HR	
Performance	Capacity (Nominal)	Cooling	kW	5.28	7.03	
			Btu/h	18,000	24,000	
		Heating	kW	5.86	7.91	
			Btu/h	20,000	27,000	
Power	Power Input (Nominal)	Cooling	W	70.00	75.00	
		Heating	W	70.00	75.00	
	Current Input (Nominal)	Cooling	A	0.38	0.40	
		Heating	A	0.38	0.40	
Fan	Motor	Type	-	Crossflow Fan	Crossflow Fan	
		Output x n	W	14 x 2	14 x 2	
	Air Flow Rate	H/M/L (UL)	CMM	14.00/13.00/12.00	15.00/14.00/13.00	
			l/s	233.33/216.67/200.00	250.00/233.33/216.67	
	External Pressure	Min / Std / Max	mmAq	-	-	
			Pa	-	-	
Piping Connections	Liquid Pipe	Ø, mm	6.35	9.52		
		Ø, inch	1/4"	3/8"		
	Gas Pipe	Ø, mm	12.70	15.88		
		Ø, inch	1/2"	5/8"		
	Drain Pipe	Ø, mm	VP25 (OD 32, ID 25)	VP25 (OD 32, ID 25)		
Field Wiring	Power Source Wire	mm ²	AWG 16 ~ 14	AWG 16 ~ 14		
	Transmission Cable	mm ²	AWG 18 ~ 16	AWG 18 ~ 16		
Refrigerant	Type	-	R410A	R410A		
	Control Method	-	EEV INCLUDED	EEV INCLUDED		
Sound	Sound Pressure* ²⁾	High / Mid / Low	dB(A)	38.0/37.0/35.0	41.0/39.0/37.0	
	Sound Power	Cooling		-	-	
Dimensions	Net Weight		kg	21.00	22.00	
	Shipping Weight		kg	25.00	26.00	
	Net Dimensions (WxHxD)		mm	890 x 230 x 575	890 x 230 x 575	
	Shipping Dimensions (WxHxD)		mm	1077 x 299 x 642	1077 x 299 x 642	
Panel Size	Panel model		-	PC2NUSMEN	PC2NUSMEN	
	Panel Net Weight		kg	4.00	4.00	
	Shipping Weight		kg	8.00	8.00	
	Net Dimensions (WxHxD)		mm	1030 x 25 x 650	1030 x 25 x 650	
	Shipping Dimensions (WxHxD)		mm	1103 x 151 x 727	1103 x 151 x 727	
Additional Accessories	Drain pump	Drain pump	- / Model	Built-in	Built-in	
		Max. lifting Height / Displacement	mm / liter/h	750 / 24	750 / 24	
	Air Filter		-	Long life filter	Long life filter	

* Specifications may be subject to change without prior notice for product improvement.

*1) Mode

- HP : Heat Pump, HR : Heat Recovery

*2) Sound pressure was acquired in an anechoic room. Thus actual noise level may be different depending on the installation conditions.

2 2 way cassette

2-3. Dimensional drawing

Unit:mm

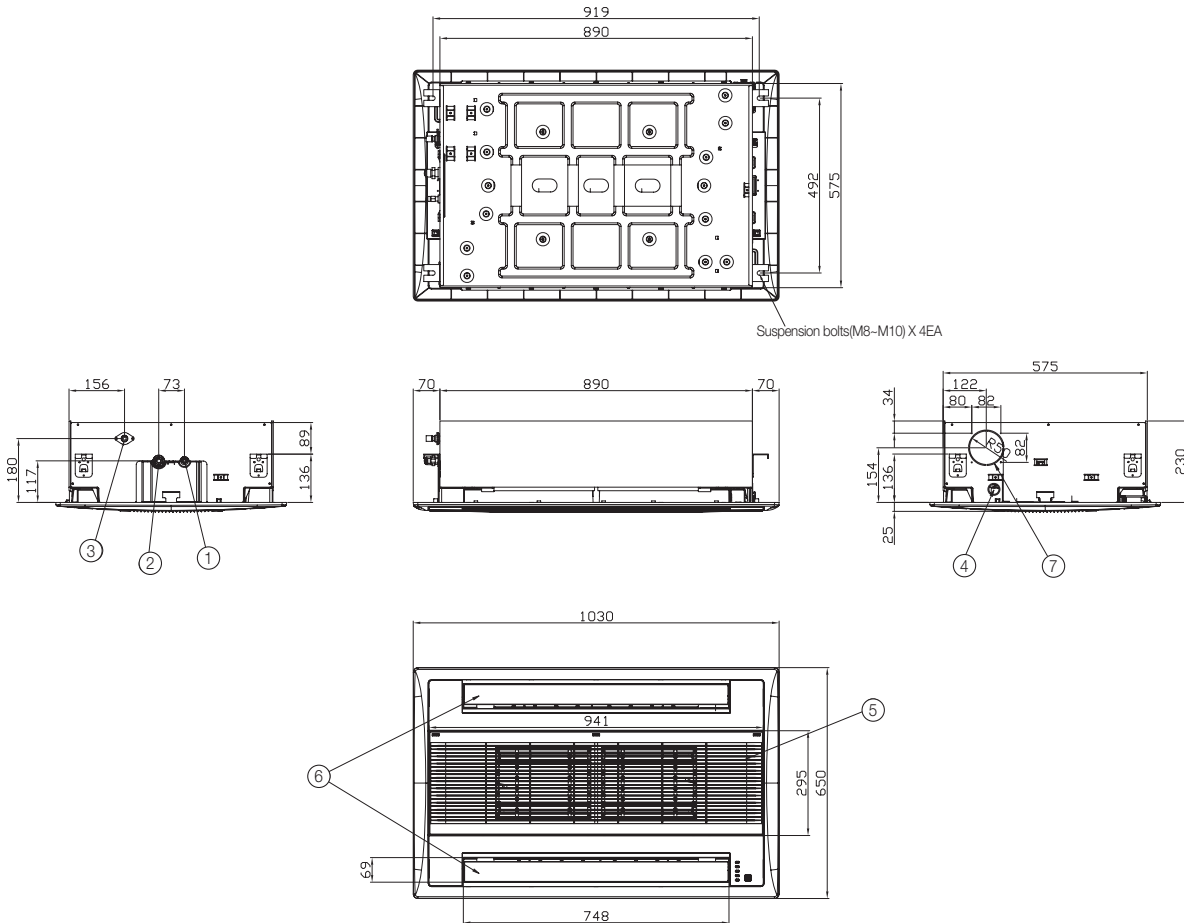

No.	Name	Description	
		018	024
①	Liquid pipe connection	Ø6.35 Flare	Ø9.52 Flare
②	Gas pipe connection	Ø12.70 Flare	Ø15.88 Flare
③	Drain pipe connection	VP25 (OD 32, ID 25)	
④	Conduit for power supply & communication wiring	-	
⑤	Air inlet grille	-	
⑥	Air outlet louver	-	
⑦	Fresh air intake	-	

2-4. Electrical wiring diagram

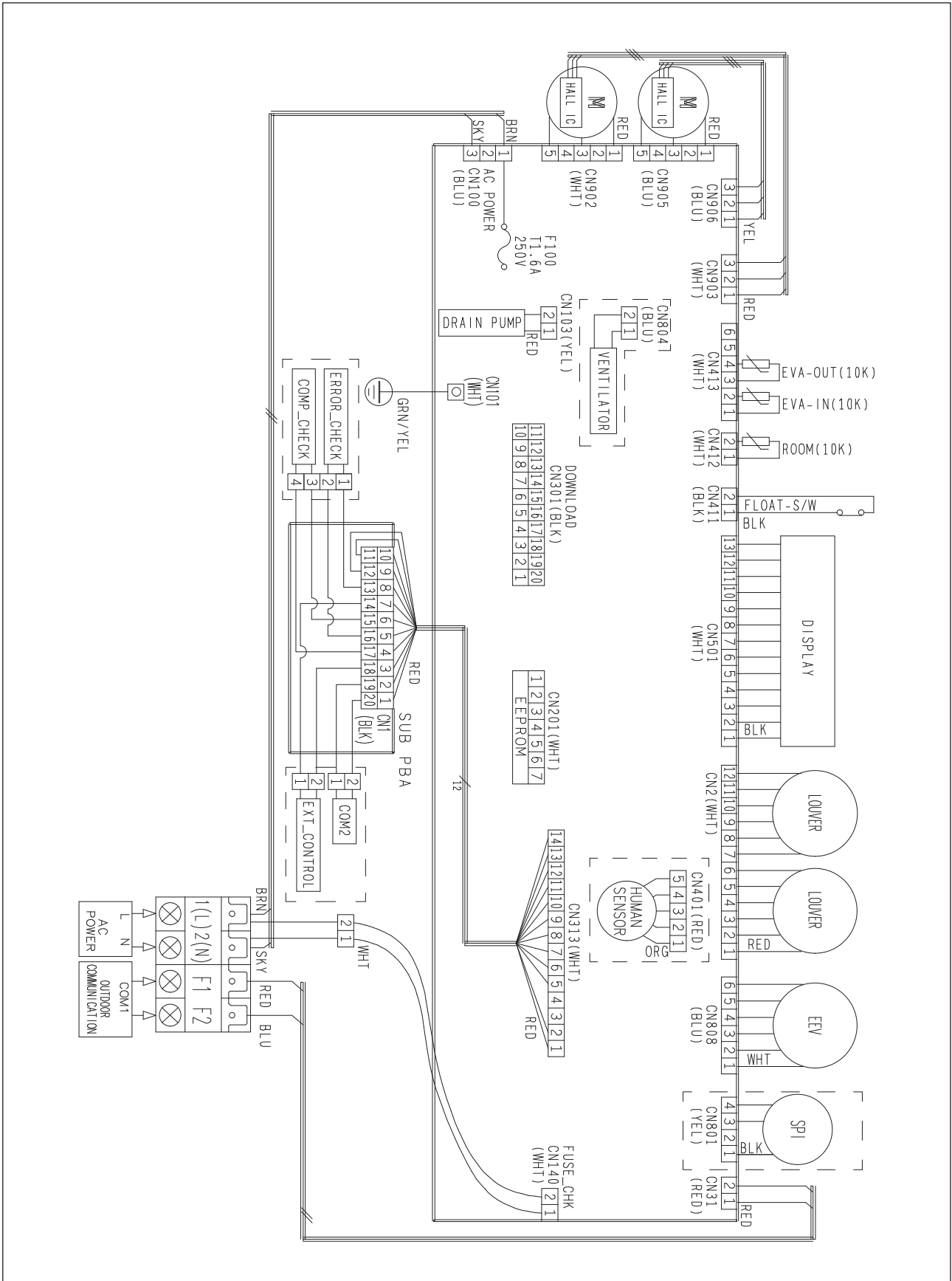

2 2 way cassette

2-5. Sound pressure level

1) Operation sound level

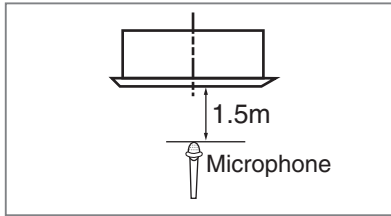

Unit : dB(A)

Model	High	Low
AM018FN2DCH***	38	35
AM024FN2DCH***	41	37

✓ Note

- ◆ These operation values were obtained in an anechoic room. Sound pressure level will vary depending on a range of factors such as the construction of the particular room where the equipment is installed.
- ◆ Operation sound level may differ depending on operation and ambient conditions.

2) NC curves

(1) AM018FN2DCH***

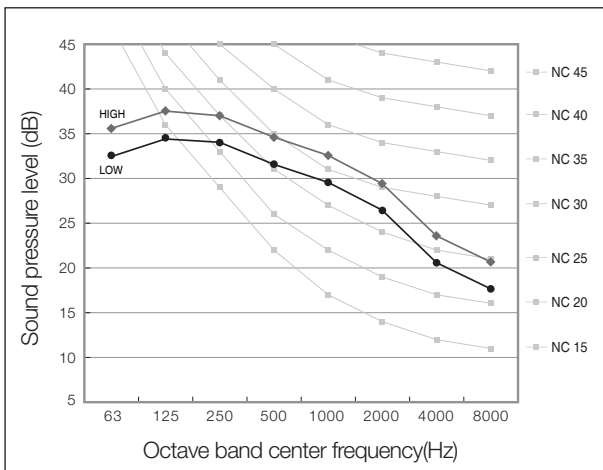

(2) AM024FN2DCH***

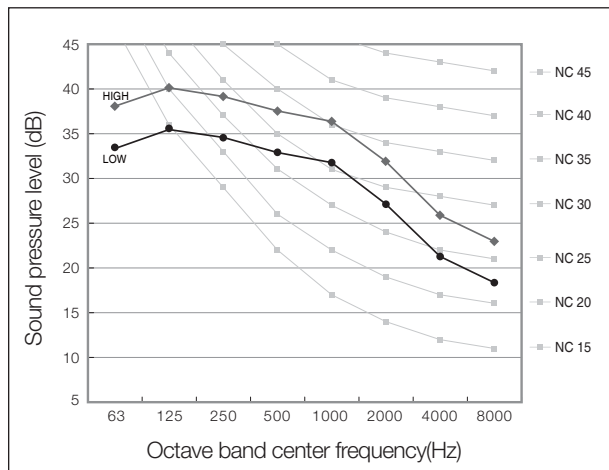

SAMSUNG

2017. 03
DBEA-13067H(A)

SAMSUNG

**Samsung Electronics Co., LTD.
Airconditioner Marketing Group/SE**

Head Office (Suwon Korea) 416, Maetan-3Dong, Yeongtong-Gu, Suwon City, Gyeonggi-Do, Korea 443-742
TEL : 82-31-200-4549 Website : www.dvmsystem.com Email: airconditioner@samsung.com

* Images and data in this book may subject to change without prior notice.